

LYSAGHT® PRODUCT CATALOGUE



LYSAGHT® ROOFING WALLING

Countless of clients across Asia rely on the quality, durability and integrity of LYSAGHT® Roofing and Walling products in making their architecture concept a reality.

From the straightforward seamless wall panels to extreme roofing lengths and curves, our comprehensive range of roofing and walling products meet the requirements of most architecturally demanding structures, without compromising on strength, flexibility or aesthetics.



ICE BSD is using LYSAGHT® FLEXLOK® COLORBOND® Gull Grey produced using Mobile Rollforming and On-Site Curving method.

RANGE OF PROFILES

CONCEALED-FIX

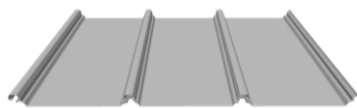

KLIP-LOK® OPTIMA

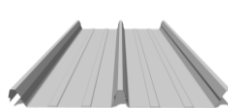

KLIP-LOK® 406



SELECT SEAM® III



PRESTIGE PANEL® II

PIERCED-FIX



SPANDEK® OPTIMA

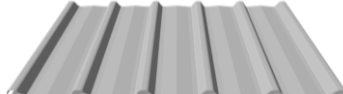

TRIMDEK® OPTIMA



TRATAS®



CURVED PROFILES:
SPANDEK® OPTIMA,
TRIMDEK® OPTIMA

SEAMING

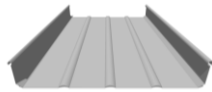

FLEX LOK®

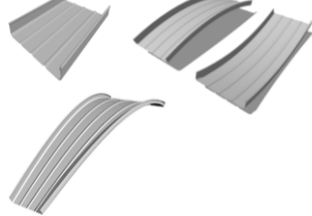

straight, tapered, curved (R+, R-), curved-tapered (R+)



LOCKED SEAM®

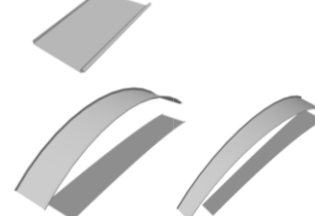

straight, tapered, curved (R+), curved-tapered (R+)



ULTRA-RIB®

STANDARD SPECIFICATION

Profile	Effective Width (mm)	Rib Depth (mm)	Minimum Roof Slope (°)	Standard Thickness (mm BMT)	Application	Curved & Tapered
KLIP-LOK® OPTIMA	980	43	2°	0.40; 0.45	Roofing	SC
KLIP-LOK® 406	406	41	2°	0.45	Roofing	SC
SELECT SEAM® III	300	25	5°	0.55	Roofing, Walling	-
PRESTIGE PANEL® II	295	25	-	0.55	Walling	- With/without sidelap gap
SPANDEK® OPTIMA	935	24	3°	0.35; 0.40	Roofing, Walling	SC; CC
TRIMDEK® OPTIMA	1015	29	3°	0.35; 0.40	Roofing, Walling	SC; CC
TRATAS®	1036	19	3°	0.35; 0.40	Roofing, Walling	-
FLEX LOK®	400	65	1.4°	0.55; 0.80 (Al)	Roofing	SM, T
LOCKED SEAM®	330	25	3°	0.55	Roofing	SM, T Convex curve only
ULTRA-RIB®	650	110	2°	0.60	Roofing	-

SC: spring curve; CC: crimp curve; SM: smooth curve; T: tapered; R+: convex; R-: concave
For other enquiries outside standard application, material and thickness, please contact us

For more detailed information
download profile datasheets



Scan QR Code
or visit our website

MOBILE ROLLFORMING SOLUTION



Mobile Elevated Rollforming (MERF)

For jobs with very long roof runs, complex shapes or both, LYSAGHT® Mobile Rollforming on-site reduces the risks in transport and handling of very long panels, eliminates step and expansion joints and allows precise matching of production with installation schedules.

On Ground Rollforming | Fixed-Based Elevated Rollforming | Rollforming On Top
| Mobile Elevated Rollforming | On-Site Smooth Curving

BLUESCOPE'S HIGH-QUALITY STEEL

LYSAGHT® range of quality roofing and walling profiles are made from BlueScope's premium materials, such as Colorbond® and Zincalume® steel.

LYSAGHT® roofing and walling are available in attractive range of colours in COLORBOND® steel and unpainted ZINCALUME® aluminium/zinc alloy-coated steel. The standard COLORBOND® steel offers a full range of contemporary colours suitable for all building projects. COLORBOND® XPD steel provides superior aesthetic qualities, and COLORBOND® ULTRA steel is intended for severe coastal or industrial environments.

Zincalume®

BlueScope proprietary metallic coating technology ZINCALUME® is superior in corrosion performance under varied conditions, when compared with other galvanized steel. ZINCALUME® comprises 55% Aluminium, 43.5% Zinc and 1.5% Silicon. The minimum coating mass of 150gr/m² offers a high-level corrosion resistance.

Cross Section of ZINCALUME® Steel

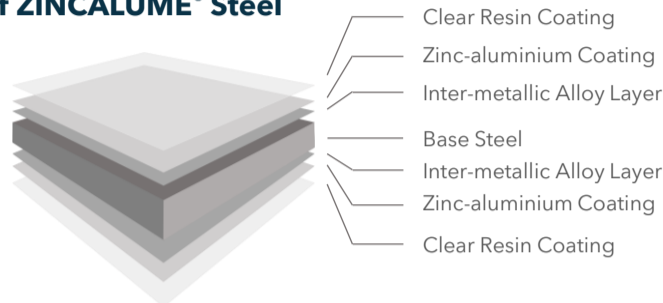

Colorbond®

BlueScope utilises optimum paint formulation and pigment blends to provide excellent long-term colour stability for COLORBOND®. The proprietary paint system is a result of extensive R&D testing, including actual field exposure testing. It has been proven that the paint system used for COLORBOND® provides superior durability against weathering and UV penetration as compared to other pre-painted steel. With **Thermatech®**, your building surface reflects more sun's rays, absorb less heat, and create a cooler surface temperature, a highly important feature for the harsh tropical climates.



Cross Section of COLORBOND® Steel

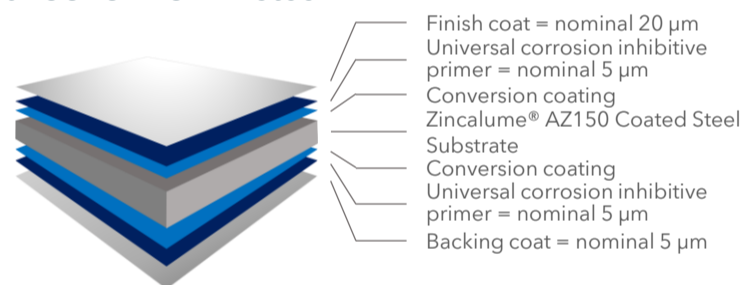

Colorbond® Standard Color*



Colorbond® MATT

COLORBOND® MATT is intelligently designed with a matt finish featuring a gloss unit of less than 10, to drastically reduce specular reflection.

*The COLORBOND® steel colour shown have been reproduced to represent actual product colours as accurately as possible. However, we recommend checking your chosen colour against an actual sample of the product before purchasing, as varying light conditions and limitations of the printing process may affect colour tones.

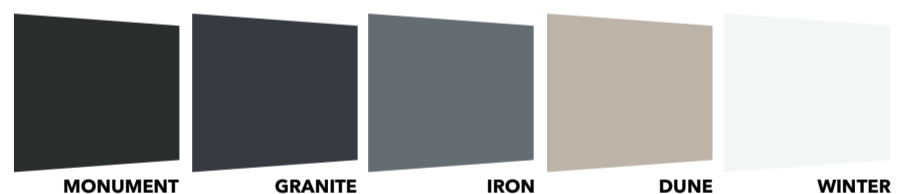

WARRANTIES

- Material warranties cover the material those products are made from, such as **ZINCALUME®** steel, **COLORBOND®** steel.
- Warranties are available against corrosion to perforation by weathering in the natural elements, and against paint flake and peel.
- Warranty terms and conditions apply.
- Warranties are not available for all products and applications.
- The duration and terms and conditions of available warranties vary according to product use and application.

INHERENT SURFACE WAVINESS

Oil Canning can be defined as a perceived waviness in the flat areas of metal roofing and metal cladding panels. Generally, the period and amplitude of the wave depend on the continuous width of the flat section of the profile. Oil canning is an inherent part of light gauge cold formed metal products, particularly those with broad flat areas. Since many uncontrollable factors are involved, no manufacturer can realistically assure the total elimination of oil canning. With careful attention to the production and selection of material, to the panel design, and to installation practice, oil canning can be effectively minimised. Unless specific tolerances have been incorporated into the contract documents and accepted by the panel provider and panel manufacturer, and if reasonable precautions have been taken, oil canning is not grounds for panel rejection.



Manggarai Station is using LYSAGHT® FLEXLOK® COLORBOND® Gull Grey produced using Mobile Rollforming and On-Site Curving method.

LYSAGHT® TRUSS & FRAME SYSTEM



SMARTFRAME®

Lysaght's SMARTRUSS® and SMARTFRAME® are innovative, fast, efficient and well-engineered light weight steel truss and framing systems for modern construction.

The systems offer durability, affordability, strength, stability and compatibility with the traditional building systems. Made from BlueScope's TRUECORE® G550 Steel, LYSAGHT® SMARTRUSS® and SMARTFRAME® is backed by a material warranty, unmatched by conventional truss material. It provides a lightweight alternative to timber roof trusses and is competitively priced as the system's structural integrity leads to lower lifetime costs.

Advantages of SMARTRUSS® and SMARTFRAME®

- ✓ Strong
- ✓ High buildability score
- ✓ Lightweight
- ✓ Durability
- ✓ Design Flexibility

LYSAGHT® SMARTRUSS® and SMARTFRAME® designs are supported by **SUPRACADD® detailing software.**

- ✓ Model the geometry
- ✓ Designs the wall frames and roof trusses and
- ✓ Facilitates truss structural computation

STANDARD SPECIFICATION

Profile		BMT (mm)	Yield Strength
C75sa	Roof Truss, Wall Frame	0.45; 0.60; 0.75	550 MPa
TS35	Roof Batten	0.45	550 MPa
TS30	Roof Batten	0.45	550 MPa

For other enquiries outside standard application, material and thickness, please contact us



Flange width: 32.5mm & 34mm

Material

Truecore®



AZ150

BLUESCOPE ZACS

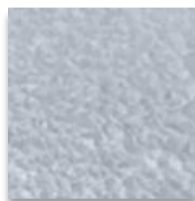

AZ100

TRUECORE® and **BLUESCOPE ZACS®** G550 steel are hot-dipped aluminium zinc-coated structural steel coated with 55% Al, 43.5% Zn and 1.5% Si, with a guaranteed minimum yield strength of 550 Mpa.

TRUECORE® steel manufactured using blue-tinted resin with AZ150 coating class and **BLUESCOPE ZACS®** steel manufactured using clear resin with AZ100 coating class.

SUPRACADD® has been certified as a software which comply with technical provision for limit state cold-formed steel structure design.

Australian Limit State Code:
AS/NZ 4600:2005
AS/NZ 1170:2002

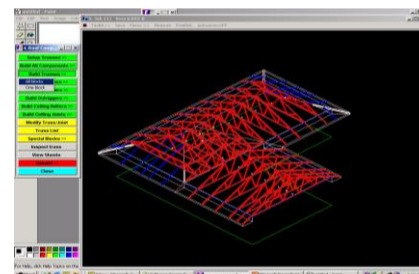

Roof Shape Modelling

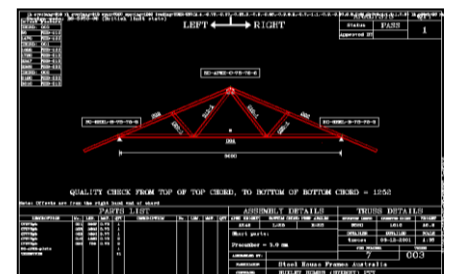

Fabrication Drawing

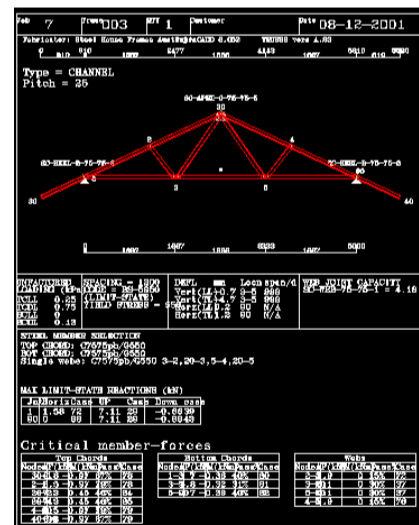

Engineering Report



HAKI Recommendation Letter, 2003



SMARTRUSS® light weight steel roof truss application



SMARTFRAME® light weight steel houseframing application

LYSAGHT® STRUCTURAL COMPONENTS



LYSAGHT® SMARTDEK® is a new innovative steel decking profile that brings greater economy and design freedom to building with composite concrete slabs.

The profile has been specifically developed for Australian high tensile steels - which makes SMARTDEK® one of the best performing "W" profiles in the world. This profile is designed to meet your requirement availability for diverse building needs. This resulted in a new innovative and optimized shape for SMARTDEK®, having flange stiffeners and deep embossments, which act as web stiffeners, to increase the load carrying capacity. Due to the large depth of the profile, an increase of the flexural rigidity reduces deflections.

SMARTDEK® is supported by excellence and PC based software. MEGAFLOOR™ software is an ultimate tool to design decking as formwork and composite for optimum result using empirical equation.

STANDARD SPECIFICATION

BMT (mm)	Coating	Yield Strength (MPa)
0.70	Zinc-coated 275 gr/m ²	550
1.00		550
1.20		450

For other enquiries outside standard application, material and thickness, please contact us

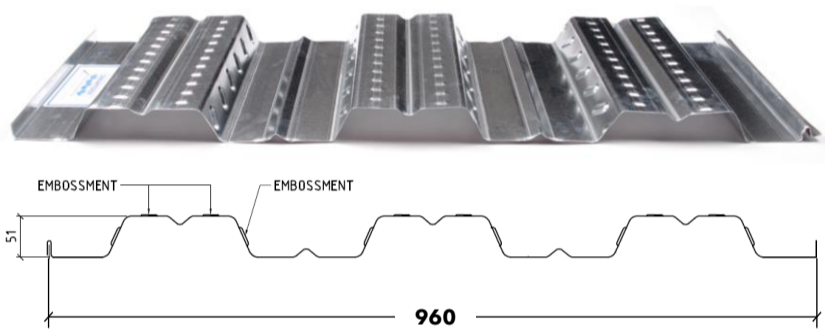

WHY SMARTDEK®?

- ✓ Research and Development Support
- ✓ Product Recommendation and Design to Suit Your Specifications
- ✓ Quality Assurance - Material & Manufacturing Process
- ✓ Worldwide Project Experience

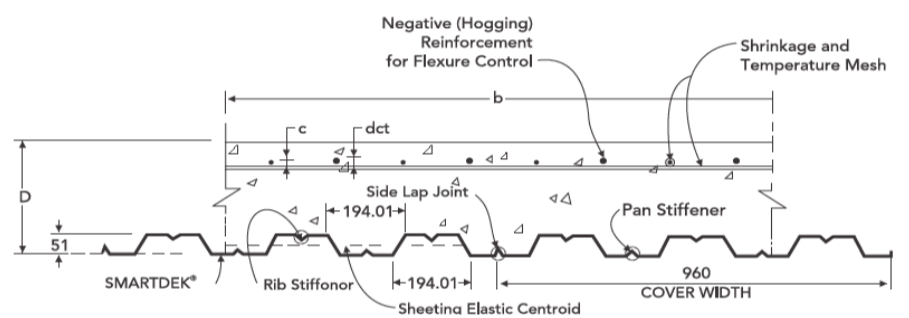

LYSAGHT® ZED & CEE Purlins and Girts

LYSAGHT® Zed and Cee sections are accurately roll-formed from high-strength zinc-coated steel to provide an efficient, lightweight, economical roofing and cladding support system for framed structures.

LYSAGHT® purlins are roll-formed into two standard shapes, Z and C sections. Both perform effectively and in many instances the choice comes down to personal preference.

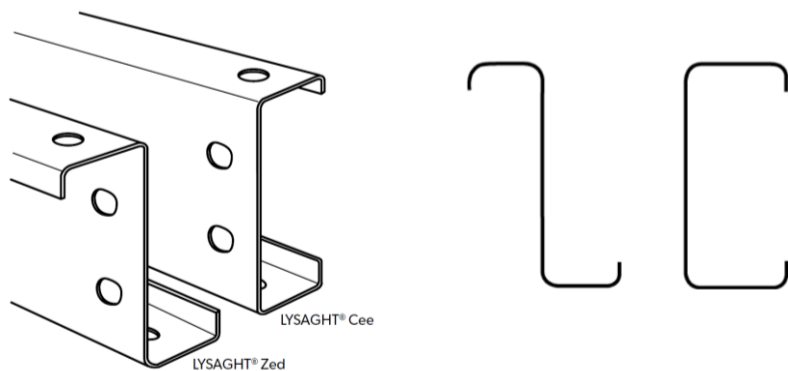

LYSAGHT® Zed sections may be used over single spans, lapped continuous and unlapped continuous spans in multi-bay buildings. Lapped continuous spans result in a considerable capacity increase in the system.

LYSAGHT® Cee sections may be used in single spans and unlapped continuous spans in multi-bay buildings. Cee sections are ideal as eave purlins or where compact sections are required for detailing. Cee sections cannot be lapped.

STANDARD SPECIFICATION

Nominal Section Size (mm) Zed & Cee	Coating Type & Mass (gr/m ²)	Yield Strength (MPa)	BMT (mm)
150	Z 275	450	1.2; 1.5; 1.9; 2.4
200	Z 275	450	1.5; 1.9; 2.4
250	Z 275	450	1.9; 2.4
300	Z 275	450	2.4; 3.0
350	Z 275	450	3.0

Standard AS 1397-1993

For other enquiries outside standard application, material and thickness, please contact us

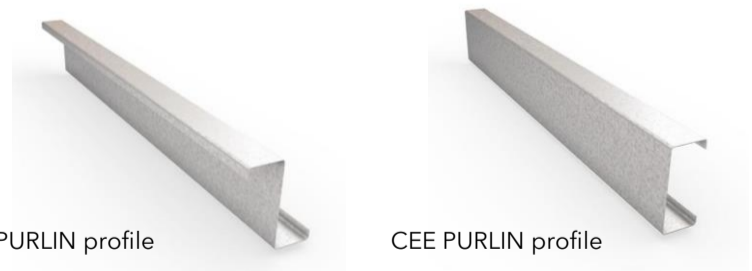

Patimban Port Office, Subang is using LYSAGHT® Cee Purlins as main structure for Pre-Engineered Building System



PT NS BlueScope Lysaght Indonesia

📍 Office & Factory:

Bekasi (Cibitung Factory)

Jalan Irian blok DD2-2, Kawasan Industri MM2100, Cikarang Barat, Bekasi, JAWA BARAT

Sidoarjo

Jalan Panglima Sudirman No.17, Menyanggong, Kletek, Taman, Sidoarjo, JAWA TIMUR

Medan

Jalan Pulau Palu No.28, Kawasan Industri Medan Tahap I, Medan, SUMATERA UTARA

☎ +62 21 8998 2965

✉ Lysaght.Indonesia@bluescope.com

🌐 **WWW.LYSAGHTASEAN.COM**

PRODUCT DESCRIPTIONS

All descriptions, specifications, illustrations, drawings, data, dimensions and weights contained in this catalogue, all technical literature and websites containing information from Lysaght are approximations only. They are intended by Lysaght to be a general description for information and identification purposes and do not create a sale by description. Lysaght reserves the right at any time to:

- (a) supply Goods with such minor modifications from its drawings and specifications as it sees fit; and
- (b) alter specifications shown in its promotional literature to reflect changes made after the date of such publication.

DISCLAIMER, WARRANTIES AND LIMITATION OF LIABILITY

- This publication is intended to be an aid for all trades and professionals involved with specifying and installing Lysaght products and not to be a substitute for professional judgement.
- Terms and conditions of sale available at local Lysaght sales offices.
- Except to the extent to which liability may not lawfully be excluded or limited, BlueScope Steel Limited will not be under or incur any liability to you for any direct or indirect loss or damage (including, without limitation, consequential loss or damage such as loss of profit or anticipated profit, loss of use, damage to goodwill and loss due to delay) however caused (including, without limitation, breach of contract, negligence and/or breach of statute), which you may suffer or incur in connection with this publication.

® product and product brand names are registered trademarks and ™ product and product brand names are trademarks of BlueScope Steel Limited.

The LYSAGHT® range of products is exclusively made by or for BlueScope Steel Limited.

BlueScope and the BlueScope brand mark are registered trademarks of BlueScope Steel Limited.

Follow Us!

📷 LYSAGHTID

🏢 NS BlueScope Lysaght Indonesia

